

Check

Series H127

Performance Features

- Precision cast body and exquisite appearance
- Full bore
- Bolted bonnet
- Good sealing
- Long life
- Easy maintenance
- Cleaned and degreased for oxygen service. Please contact us for other applications.

Specifications

- **Design Standard:** DIN3356, BS6364
- **Size:** 1/2" (DN15) ~ 8" (DN200)
- **Rating:** PN20 ~ PN110
- **Temperature:** -196° ~ +80°
- **End Connection:** BW, SW, Flange
- **Service:** LNG, LO₂, LN₂ etc.
- **Test Standard:** BS6364.
- **Body:** Austenitic stainless steel (casting/forging)
- **Disc:** ASTM A182 F304/F316
- **Bonnet:** stainless steel assembly parts
- **Sealing:** PCTFE
- **Spring:** INCONEL X-750.

Main Parts & Materials

Connections & Dimensions

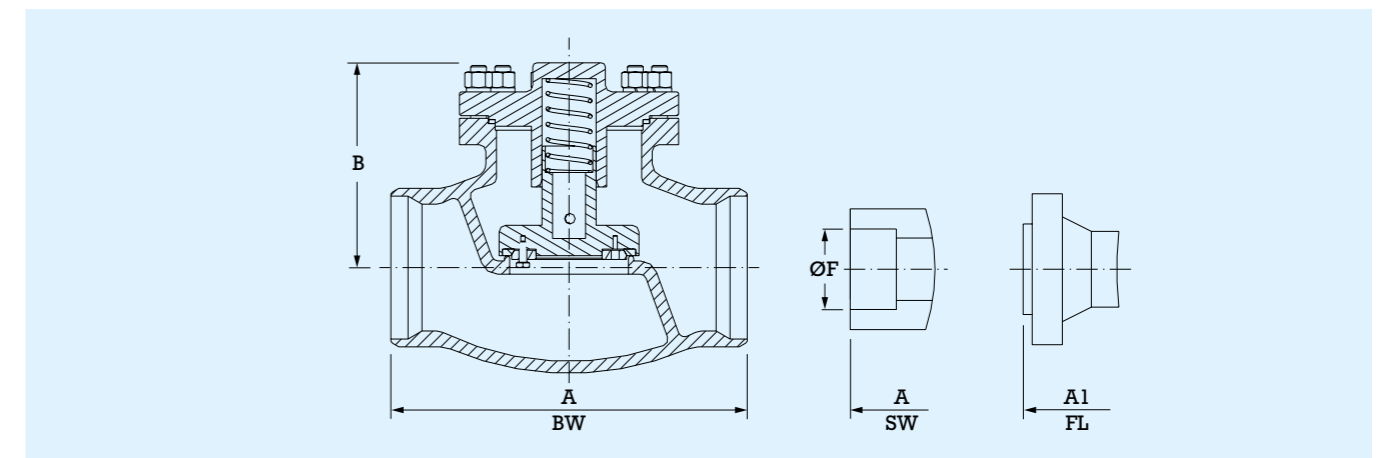

PN6~PN50

mm	Size	inches	A	A1	B	F	Cv	Kv
15	1/2		80	108	68	21,3	4,62	4
20	3/4		100	117	87	26,9	6,94	6
25	1		100	127	87	33,7	11,56	10
32	1 1/4		110	140	100	42,4	17,34	15
40	1 1/2		125	190	110	48,3	26,56	23
50	2		165	250	115	60,3	30,28	35
65	2 1/2		190	290	127	-	69,36	60
80	3		220	310	155	-	104,04	90
100	4		270	350	162	-	187,27	162
125	5		350	400	277	-	376,86	326
150	6		350	406	277	-	424,25	367
200	8		460	600	362	-	790,7	684

PN63~PN110

mm	Size	inches	A	A1	B	F	Cv	Kv
15	1/2		80	165	80	21,3	4,62	4
20	3/4		100	190	100	26,9	6,94	6
25	1		100	216	100	33,7	11,56	10
32	1 1/4		110	229	115	42,4	17,34	15
40	1 1/2		125	241	120	48,3	26,56	23
50	2		165	292	125	60,3	30,28	35
65	2 1/2		190	350	140	-	69,36	60
80	3		220	356	165	-	104,04	90
100	4		270	432	175	-	187,27	162
125	5		350	508	290	-	376,86	326
150	6		350	559	290	-	424,25	367
200	8		460	660	380	-	790,7	684

Note:

1. Swing type and Axial-Flow type please consult GRV Manufacturer.
2. All dimensions are in mm.

